

## VARIORIP 310

The intelligent concept  
for profitable cutting



# VarioRip 310: The fast and simple way to maximum productivity

The customers' demands are increasing. Changing applications call for a high degree of flexibility. More than ever before, today ripping must be an open system. The VarioRip equips you well, irrespective of whether it is a multi-blade or optimising rip saw. The robust, reliable model already stands out in the standard version with high quality equipment and it is extremely convenient to operate. If required, numerous intelligent options extend your VarioRip to become a high performance system, enabling you to make a clever start into timber optimisation.



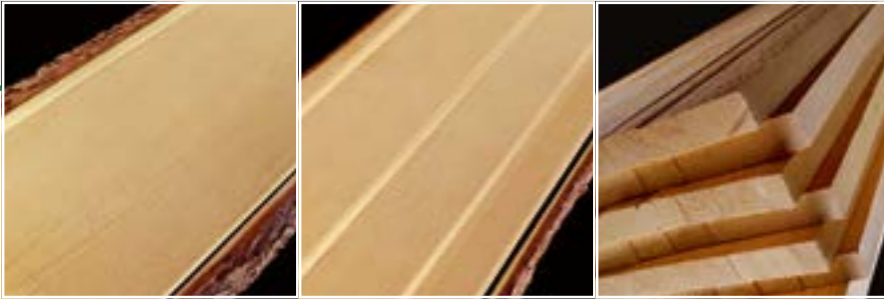

Ripping to width plays a key role in working with solid wood because optimised ripping means minimised costs. We have the concepts to put you right up front in this competition. Flexible, high performance systems tailored individually to meet your requirements. Yet they are convenient to operate, and can be set up in the shortest possible time. They are also extremely profitable and ideal for all types of enterprises – from interior trim to furniture manufacturers, from glued-up panels to saw mills.



**With the VarioRip you are a cut above the competition:**

- Optimal cutting quality
- Glue-joint cut
- High productivity and economic efficiency
- Wide range of applications
- Excellent operating convenience
- Optimal for integration in system solutions
- Robust, durable design
- Maximum operator safety

## Combined pressure unit: Ideal material control

Tough everyday operation is our benchmark. The combined pressure unit equips you perfectly for difficult tasks. Big, heavy pressure rollers - combined with the proven Raimann pressure board - fix the timber reliably on the transport chain. This guarantees absolutely precise material guidance even with heavy and warped timbers.

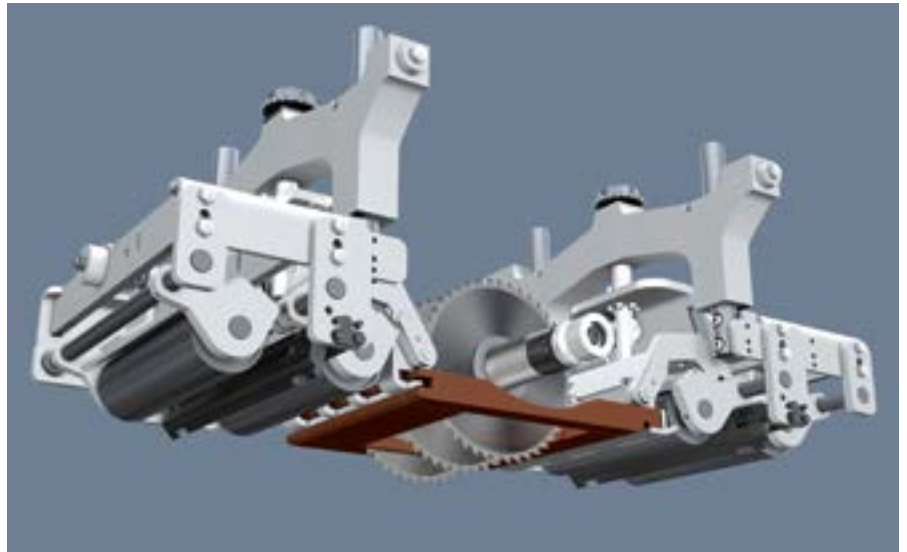

## Chain feed: Reliable conveyance of any type of material



Reliable material conveyance is the crucial prerequisite for optimal material yield, long tool service lives and high productivity. The chain feed on your VarioRip is exactly the right equipment. The entire surface of the workpiece rests on the chain and is conveyed precisely through the saw. Prisms on both sides ensure an absolutely straight, play-free chain guide. The closed chain prevents splinters from jamming and thus guarantees high operating reliability.

## Quickfix: Minimal set-up times



You have never before retooled a machine as easily and conveniently as with the patented Quickfix fast-release system. Everything is done in the shortest possible time: Release hydraulic tension, insert wood samples. Shift saw blades on the arbour, apply hydraulic tension. Done. Without any bushings, spacers or tools.

## SafetyPlus: Maximum operator safety

SafetyPlus guarantees maximum operator safety. The patented Kevlar and polyurethane protection concept complements the conventional types of kick-back protection. The hazard zone is optimally sealed.

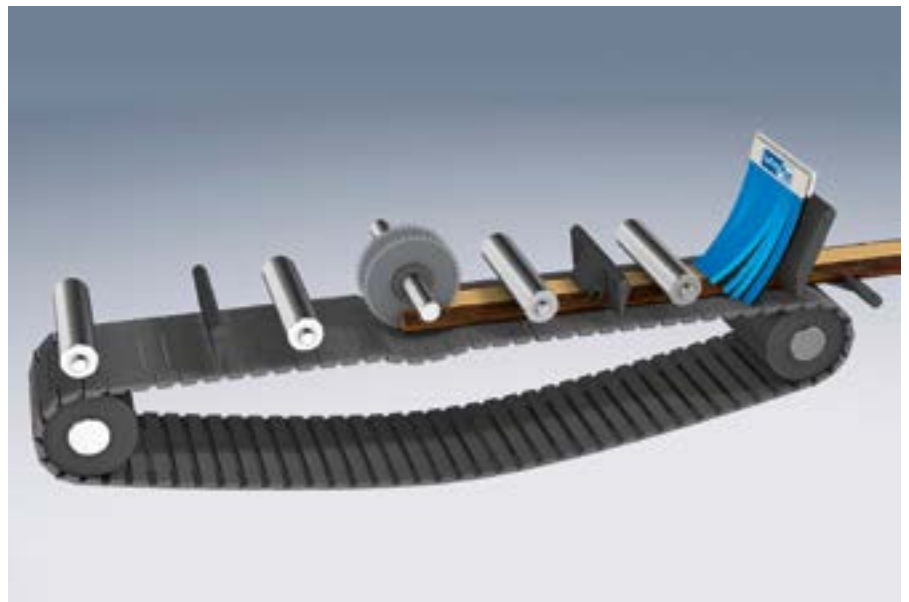

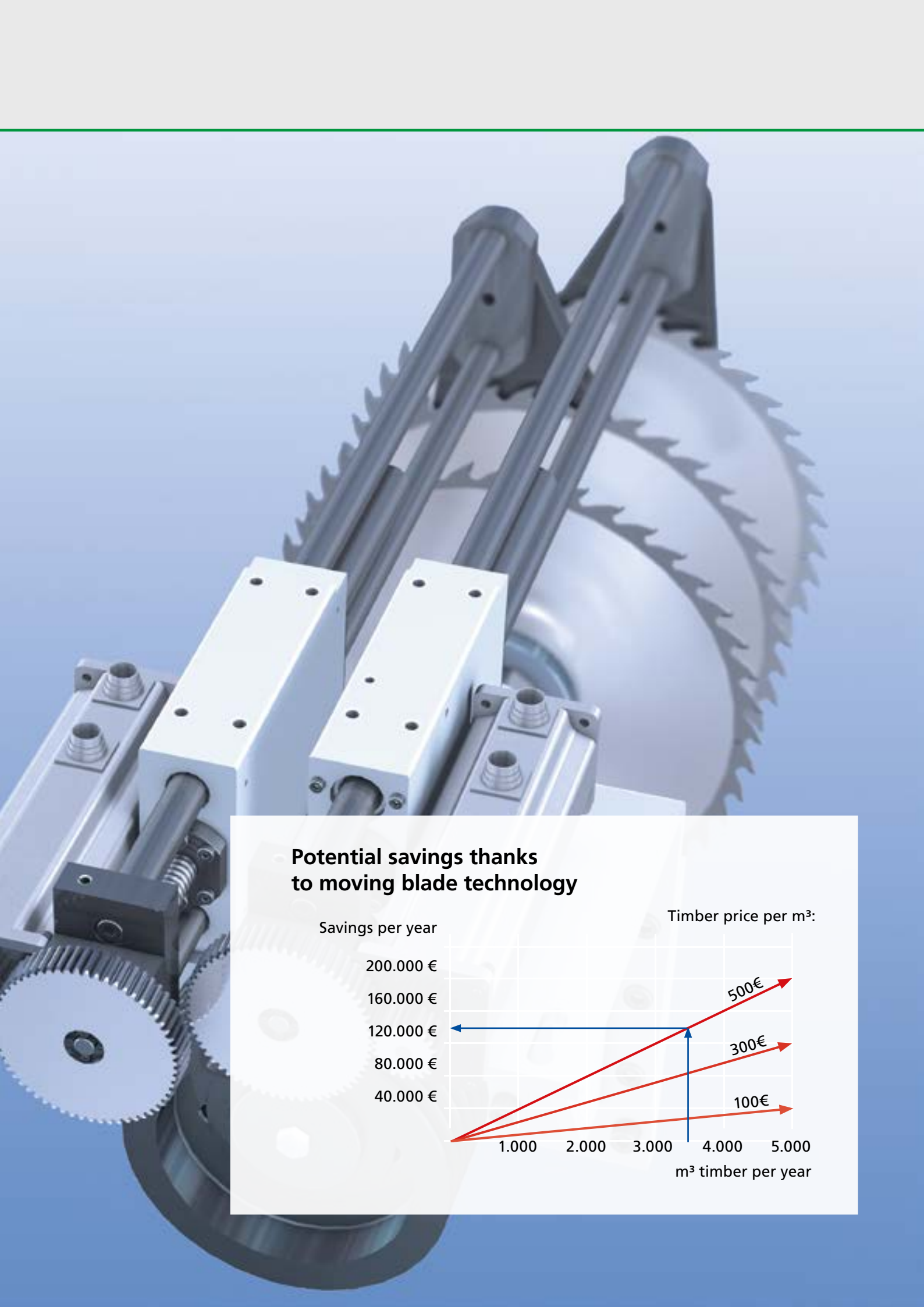

### Potential savings thanks to moving blade technology

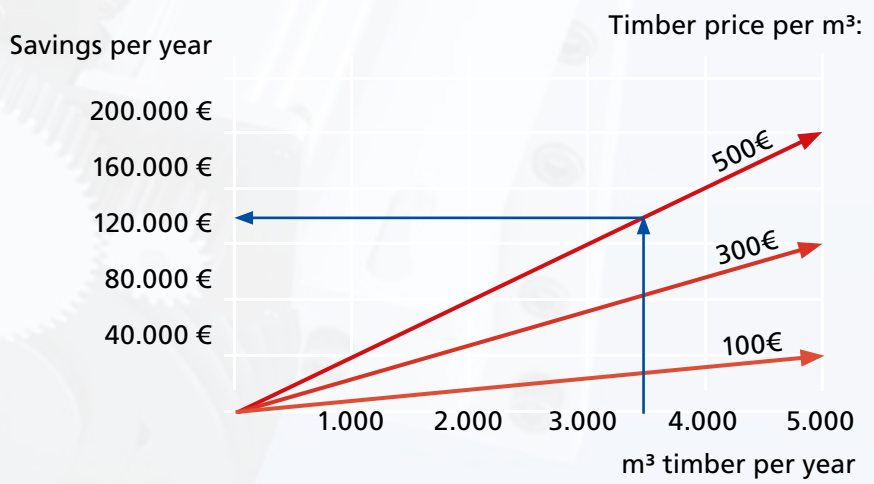

# Moving blade technology: Unlimited flexibility

With a conventional fixed arbour setup, varying board widths, qualities and defects lead to material waste in the range of 8% on average. By contrast, the moving blade technology of the RaimannLine ensures that the raw material is used efficiently. With one or two moveable saw blades you adapt your VarioRip individually to any board. Due to this optimised timber yield, material and storage costs are reduced significantly. Timber optimisation is equal to cost minimisation.

Moreover, the virtually unlimited number of possible combinations of fixed and moveable saw blades increases

the flexibility of your production and thus facilitates just-in-time and small-batch production.



## Possible combinations

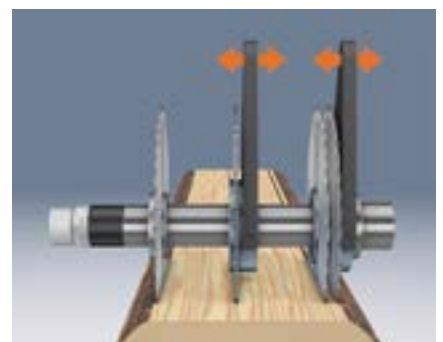
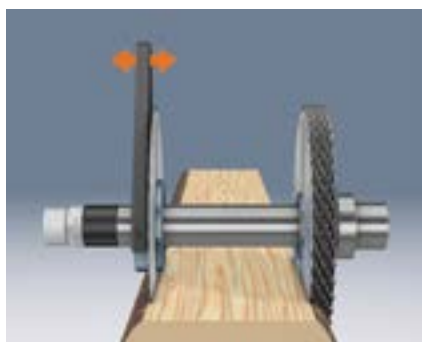
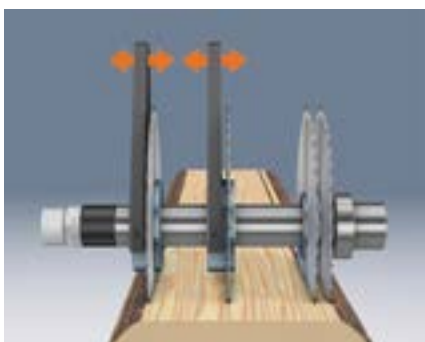
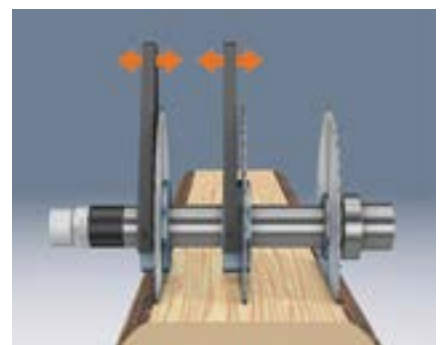
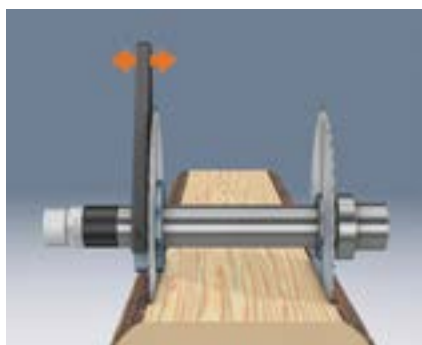
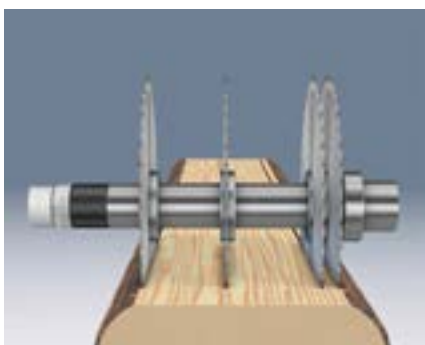

# ProfiCut Direct: Everything under control

The ProfiCut Direct control system is the foolproof way to a higher timber yield. It also offers many functions which can be performed conveniently via a touch screen or joystick:

- Cutting list entries and statistics for easy production planning
- Machine diagnostics and the modification of parameters for effortless maintenance
- Selection of:
  - Variable widths, e.g. for edging
  - Fixed dimensions, e.g. ripping widths according to a cutting list
- Online service (option: RaiCon) for easy maintenance and high availability



## RipAssist: Automatic width optimisation

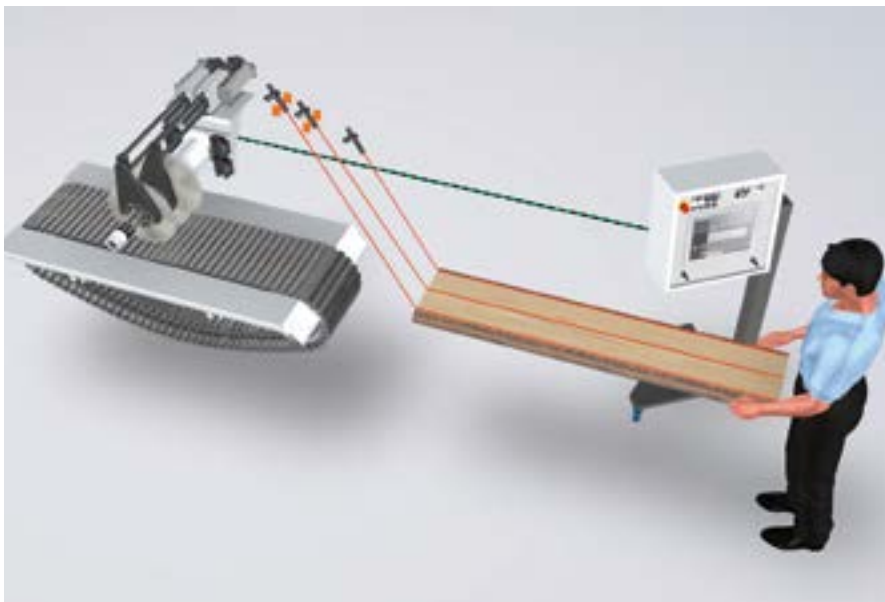

You have never got the optimum out of your raw material as easily as with RipAssist:

1. Align board to fixed laser
2. Mark the board width
3. Done!

RipAssist automatically calculates the optimal ripping solution for each board and positions the movable saw blades accordingly. The operator checks the result via the laser lines on the board and can correct the solution by means of the joystick or touch screen, if necessary.



# Overview table VarioRip: Standards and options

The matrix shows the important technical features of the VarioRip 310. The expert at Weing for the RaimannLine will be happy to provide you with more detailed information.

	● Standard	○ Option
Max. cutting width	310 mm	
Chain width	340 mm	
Max. number of movable saw blades	2	
Max. outlet width	650 mm	1,100 mm
Max. cutting height with Quickfix flanges (without pressure board)	95 (110) mm	
Max. cutting height with movable saw blades (without pressure board)	85 (100) mm	
Min. timber length with pressure board in use	410 mm	320 mm
Max. feed speed	5 – 35 m/min	
Motor	22 kW	30 kW, 37 kW
Number of pressure rollers	4	
Saw blade diameter min./max.	300 mm / 350 mm	
Weight	2.060 kg	
Dimensions: length x width x height	1,75 x 1,75 x 1,87 m	
Working height	850 mm	
Dust extraction diameter	250 mm	
Required dust extraction speed	30 m/sec	
Required dust extraction volume	5.300 m³/h	
Noise emission at the machine in idle motion / in operation *	LpA = 77 / 82 dB(A)	
Sound volume in indle motion / in operation *	LpA = 93 / 97 dB(A)	
Quickfix incl. 4 clamping flanges and 4 saw blades (gang rip only)	●	
Motorised height adjustment of saw arbour	●	
Motorised height adjustment of the pressure unit	●	
Lasers moving blade ripsaw	●	
Lasers fixed gang ripsaw		○
ProfiCut Direct controls		○
RipAssist		○
RaiCon		○
High performance chain		○
Spikes		○
Rubber inserts		○

\* according to EN 1870-4 and ISO 7960 annex Q; uncertainty constant value K = 4 dB(A)

Subject to technical modification. Statements and pictures in this brochure may also include optional extras which are not included in the standard serial equipment. Some of the photos show the machine with the protective covers removed.

# WEINIG quality: The sum of many properties



Not many companies succeed in becoming a brand. WEINIG has succeeded in doing so. Trust plays a central role here. And the ability to prove this trust on a daily basis with our customer. We do this with quality. From product development to our supply of spare parts, from materials used to our worldwide service network. Based on employees noted for their expertise and passion for the product. Utmost care in assembling machines is part of this, as is continuous training. In order to maintain WEINIG's high standards we focus on vertical integration and independent quality management. Based on the world famous kaizen method, our production undergoes a continuous optimization process.

But WEINIG quality also means aligning production for the future with open machine systems, energy efficiency and sustainability. All these characteristics blend to create a product praised by our customers around the globe as outstanding. We call it 100% WEINIG quality.

# WEINIG service: Very close to customers



Customer relations are good. But we have a better word for it: WEINIG service. Supported by people who want to share their enthusiasm for wood with others. And when experts start talking together, a solution is not far away. This is why WEINIG service focuses on dialog with you, on outstanding training and a local support presence. The global WEINIG service network is so densely spread like no other in the sector. For you this means easy communication in your own language and rapid help. Whether by telephone or by a technician on site. We are here for you when you need it. You can order any spare part you need via the hotline for rapid delivery - even old models.

You will be advised in detail by a professional WEINIG expert in your country. In our individually tailored training programs you can find out how to optimally exploit the capabilities of your machine. Our specialists are always open to your production tasks.

- Subsidiaries in all continents of the globe
- Local WEINIG expert who speaks your language
- Mobile team of over 300 service technicians
- Spare parts via the hotline
- Professional advice by specialists via the hotline
- 6 day service
- Individually tailored training program
- Service agreements on request
- International ExpoCenter
- Financing to suit your needs

# VARIORIP 310

---



## **Product Unit Cutting**

RAIMANN HOLZOPTIMIERUNG  
GMBH & CO.KG  
Weisserlenstrasse 11  
79108 Freiburg  
Germany

Phone +49 761 13033-0  
Fax +49 761 13033-17  
info-cutting@weinig.com  
www.weinig.com